



## INSITE: Remote Dispensing Unit

500sl Model Specification Sheet

## INSITE™

**InSite™ Remote Dispensing System** is part of a complete solution designed to automate medication dispensing at remote locations. The complete system helps manage your medication inventory and provides accurate order entry, integrated patient information, secure storage, and automated, on-demand dispensing.

## INSITE: Remote Dispensing System Specifications

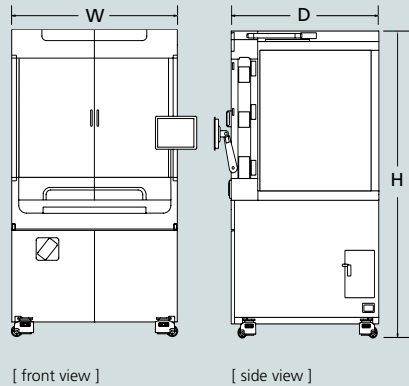

[ front view ] [ side view ]

### DIMENSIONS

- Height:** 91" / 2317mm
- Width:** 43" / 1087mm
- Depth:** 47.5" / 1207mm
- Weight without Canisters:** 2557 lbs
- Weight with Canisters:** 3006 lbs

### SITE REQUIREMENTS

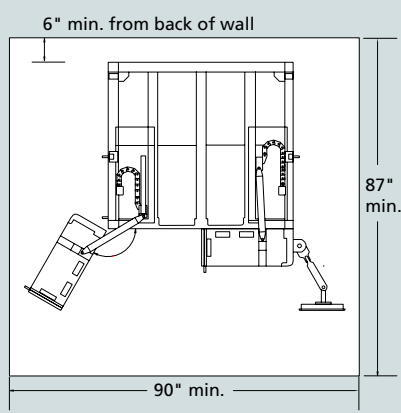

Prior to installation, a site survey will be completed to ensure there are no physical obstructions that would affect installation.

Additional space may be required for installation. Actual space required may vary.

**InSite™ Remote Dispensing System** features powerful software and durable hardware components, designed to improve the control and efficiency of your medication storage, and dispensing process. Our automated system will increase accuracy, reduce the time needed to prepare for daily medication passes, and increase patient safety.

The software is efficient, easy-to-use, and provides workflow guidance to help prevent medication errors. The medication packaging system allows user-defined, patient-specific labels on each dose packaged.

The InSite system uses powerful software to enable real-time integration with your current management system. It helps ensure stored medications are accessed by the right pharmacy staff, packaged for a specific patient, and tracked at delivery.

The InSite 500sl automates up to 500 oral solid medications in a single medication dispensing unit. The system is compact and easy to use, and it can recognize priority orders for immediate packaging. The user-friendly touch screen interface provides directed workflow to improve overall efficiency.

### STORAGE CAPACITY

- Canisters:** 500
- Canister Type and Number:**  
Short: 288  
Tall: 132  
Tall-Extended: 80

Note: Canister size is determined by the medication dimensions. Short canisters may be used in Tall or Tall-Extended locations.

### FEATURES

- Color:** Light Grey / Light Blue
- Lockable Front Door:** Yes
- Control Interface (type):** LCD
- Control Interface Location:** Front
- Operator Interface & Display:** Yes
- Operating System:** Windows 2000 Pro, Visual C++
- Input System:** 10.4" Touch Screen
- Access Doors:** Front & Side
- UPS:** 1440 VA, 980W

### PACKAGING

- Maximum Packaging Speed:**  
Multi Dose: 50 packets/min
- Package Size:** 70x75mm
- Customizable Lines of Print:** 19 Lines
- Package Printing:** Thermal
- Custom Fonts:** Yes
- Tablet Detection System:**  
Infrared Beam Detection System

### SYSTEM REQUIREMENTS

- Power Consumption:** 200W (Max 900W)
  - Power Supply:** 120V/60Hz
  - Operating Temperature:** 32°F to 104°F (0°C to 40°C)
  - Humidity Range:** 10% to 80%, non-condensing
  - Altitude Range:** Sea level to 6561 ft (2,000m)
- Compliance Note: FCC 47 Part 15, Subpart B  
ETL Certification (complies w/UL)  
Additional Certificates As Needed

## INSITE: Remote Dispensing System Features

### ACRS-II Chip

The Automatic Canister Recognition System (ACRS) uses an installed chip to establish a unique identifier for each canister. InSite looks for the pharmacist-checked medication identifier, not the canister location, so the canisters can be placed in any open InSite packaging position. ACRS improves safety by helping to eliminate errors.